

SmartHear: A Smartphone-Based Remote Microphone Hearing Assistive System Using Wireless Technologies

Yu-Cheng Lin, Ying-Hui Lai, Hsiu-Wen Chang, Yu Tsao, *Member, IEEE*,
Yi-ping Chang, and Ronald Y. Chang, *Member, IEEE*

Abstract—In this paper, we propose a new smartphone-based hearing assistive system (SmartHear) using wireless technologies for individuals with mild-to-moderate hearing loss (HL). Our system is a stigma-free implementation of the personal frequency modulation (FM) system for people with HL, with enhanced accessibility, affordability, and customization and extension potentials. The SmartHear system consists of a smartphone running a mobile application and a Bluetooth handset coupled with the smartphone. The voice of the speaker is picked up by the smartphone placed near the speaker and transmitted wirelessly to the Bluetooth handset placed near the listener for listening. The transmission of the voice signals over radio waves overcomes the reverberation and ambient noise effects, and thus, the listener can listen from a distance with better clarity and ease. Speech intelligibility experiments demonstrate the efficacy of the proposed SmartHear system, showing an average improvement of 0.2 speech intelligibility score (on the scale of 0–1) across four typical audiograms for mild-to-moderate HL and in four signal-to-noise ratio conditions. A user survey reveals the favorable user experience with SmartHear in various dimensions, as compared to the conventional FM system.

Index Terms—E-health, frequency modulation (FM) systems, mobile applications, smartphones, wireless assistive hearing technology.

I. INTRODUCTION

LIFE expectancy has continuously increased in many countries due to medical advances, and age-related hearing loss (HL) has been one of the most common conditions affecting adults. According to World Health Organization (WHO), 15% of the world's adults and one-third of the world's population aged 65 or above have different degrees of HL [1]. According to the WHO prediction, the number of adults over 65 years old

Manuscript received January 14, 2015; revised August 28, 2015; accepted October 4, 2015. This work was supported in part by the Ministry of Science and Technology, Taiwan, under Grant MOST 103-2218-E-715-002 and Grant MOST 104-2218-E-715-002. (*Corresponding author: Ronald Y. Chang.*)

Y.-C. Lin, Y.-H. Lai, Y. Tsao, and R. Y. Chang are with the Research Center for Information Technology Innovation, Academia Sinica, Taipei 115, Taiwan (e-mail: r99525067@ntu.edu.tw; jackylai@citi.sinica.edu.tw; yu.tsao@citi.sinica.edu.tw; rchang@citi.sinica.edu.tw).

H.-W. Chang is with the Department of Audiology and Speech-Language Pathology, Mackay Medical College, New Taipei 252, Taiwan (e-mail: iamaudie@hotmail.com).

Y. Chang is with the Speech and Hearing Science Research Institute, Children's Hearing Foundation, Taipei 114, Taiwan (e-mail: yipingchang@chfn.org.tw).

Digital Object Identifier 10.1109/JSYST.2015.2490104

will triple between 2010 and 2050, and the prevalence rate of age-related HL is estimated to increase rapidly. Davila *et al.* [2] reported that 18% of older U.S. workers are experiencing HL.

HL could cause great inconvenience in life. People with HL may experience heightened difficulties in listening in noisy conditions [3]–[6]. People with mild HL may lose 50% of speech in noise, and people with moderate HL may lose 50%–70% of speech in noise. Moreover, uncorrected HL may associate with loneliness, withdrawal from social activities, and sense of exclusion, leading to degraded quality of life in general [7], [8]. Lotfi *et al.* [9] showed that hearing difficulty may affect communicative relationships as well as social and emotional interactions.

For people with HL, a common prescription is hearing aids [5], which magnify sound vibrations entering the ears. However, Kochkin [10] reported that the hearing aid adoption rate was only 23% in the adult population surveyed in their study. Kochkin [11] commented that only 29% of people are satisfied with their hearing aids. There are some reasons associated with the dissatisfaction. For example, the poor performance of hearing aids in noise has deterred people from using them [12]. In addition, hearing aids have varying performance in conditions with background noise and reverberation and when listening at a distance.

Personal frequency modulation (FM) systems have been proposed to alleviate these issues. FM systems carry the sound to the ears directly from the transmitter microphone used by the speaker to the receiver used by the listener using FM, effectively overcoming the obstacles of background noise, distance from the speaker, and poor room acoustics. Popular commercial FM systems include Phonak Dynamic FM [14], COMTEK AT-216 [15], and Comfort Contego [16], [17]. Studies have shown that adults with HL prefer using FM systems in noisy conditions, and people using both hearing aids and FM systems perform better than those using hearing aids alone [18]–[20]. While the FM systems could be beneficial to people with HL, there are two limitations of commercial FM systems. First, commercial FM systems usually adopt a relatively simple one-channel linear amplification scheme to complete sound delivery (while leaving customized multichannel amplification to hearing aid processing). Second, the transmitter and the receiver of an FM system are paired when users desire to use some latest FM technologies (e.g., Phonak Dynamic FM). Furthermore, commercially available hearing aids or FM systems are quite

expensive. In one study [10], 76% of respondents revealed that financial constraint is the main obstacle to hearing aid adoption. It is therefore imperative to increase the accessibility and affordability of hearing devices, as also urged by the U.S. National Institute on Deafness and Other Communication Disorders (NIDCD) which sponsored a research working group focusing on adults with mild-to-moderate HL, as this group of people are less likely to adopt hearing aids [21].

Against this background, we propose a highly affordable, cost-effective, and accessible smartphone-based hearing assistive system (SmartHear) for individuals with mild-to-moderate HL. The proposed SmartHear system is integrated with a five-channel amplification scheme, allowing users to optimize the amplification ratio for each of the five distinct frequency channels. When compared with conventional FM systems, the multiple-channel amplification scheme of SmartHear provides more flexibility and benefits for users with various types of HL. Moreover, our system has the following features:

- 1) *Anti-stigma*: overcoming the stigma associated with hearing aids;
- 2) *Accessibility*: requiring only the user's smartphone, Bluetooth handset, and our mobile application;
- 3) *Customization*: easy customization to audio preferences or needs;
- 4) *Extension*: extensible with advanced speech–audio processing in smartphones.

The speech intelligibility experiments on four typical audio-grams for mild-to-moderate HL and four signal-to-noise ratio (SNR) conditions have demonstrated an average improvement of 0.2 speech intelligibility score (on the scale of 0–1) by adopting SmartHear. The intelligibility score is as high as 0.85, even in the most challenging SNR condition (−10 dB), with SmartHear. A user survey conducted among five participants with various degrees of HL reveals the favorable user experience with SmartHear, as compared to the conventional FM system, in many different dimensions.

The outline of this paper is organized as follows: Section II briefly reviews the current commercially available FM systems. Section III describes the system architecture for SmartHear. Section IV presents the evaluation methods. Experimental results and discussion are presented in Sections V and VI, respectively. Finally, Section VII concludes the paper.

II. CONVENTIONAL FM SYSTEMS

The FM system is a hearing assistive device that consists of a transmitter–receiver pair. The speaker wears a transmitter, whose voice is transmitted directly to the listener who wears a receiver, as shown in Fig. 1. The FM system may be coupled with hearing aids, but it can also be used alone for people with mild-to-moderate HL or with normal hearing. The FM system functions similarly to the FM radio broadcast. The transmission of the voice signals over radio waves overcomes the reverberation and ambient noise effects, and thus, the listener can listen to the voice of the speaker at a distance with better clarity. It was shown [18] that an improvement of 15–20 dB in SNR can be achieved with the FM system.



Fig. 1. Conventional FM system with a transmitter–receiver pair. The speaker wears the transmitter (left, [13]), and the listener with HL wears the receiver for listening. The receiver can be coupled with a hearing aid (middle, [13]) or standalone (right, <http://www.phonak.com>).

Studies have shown that adults with HL will have better speech perception in noisy conditions when wearing hearing aids coupled with the FM system, as compared to wearing hearing aids alone [18]. Lewis *et al.* [22] reported a consistent finding that the combination of the FM system and hearing aids equipped with directional microphones enhances perception in noisy conditions in adults with HL. If adults were to choose their preferred hearing assistive device for listening in noisy conditions, their choice is hearing aids coupled with the FM system [18]. For children with HL, the FM system can effectively improve speech intelligibility for children with a wide spectrum of HL conditions [23]–[25]. Despite the prospects of its practical use, the FM system has the limitations of unappealing appearance (stigma) and high cost (around NT\$80 000 or US\$2600 according to the local market), which results in its lower adoption rates than promised by its benefits. According to a report by Sonova Holding AG [26], which is the largest manufacturer of the FM systems, hearing assistive wireless communication products, including the FM systems, account for only 5% of the company's total sales of hearing aid products.

With the advances of wireless technologies and the prevalence of smartphones, there is a potential to implement the working principles of the FM system on smartphone platforms that promise more affordability and less stigma and, consequently, a greater potential for wider acceptance. In the following, we describe the proposed system that incorporates a variety of desired features for future smartphone-based assistive listening devices.

III. SYSTEM ARCHITECTURE FOR SMARTHEAR

The system architecture of SmartHear is shown in Fig. 2, where a person with HL (shown at the right) wishes to listen to the talker (shown at the left) with better clarity and ease using SmartHear. The listener places his/her smartphone near the talker (in the figure, the talker is shown holding the smartphone in his hand) and wears his/her Bluetooth handset. The talker's voice is captured by the microphone of the smartphone and converted from an analog signal to a pulse-code-modulated (PCM) digital signal. The PCM signal is sent to the Bluetooth transmitter in the smartphone, where the PCM electrical signal is transformed into radio waves in the unlicensed industrial, scientific, and medical (ISM) band at 2.4–2.5 GHz. A synchronous

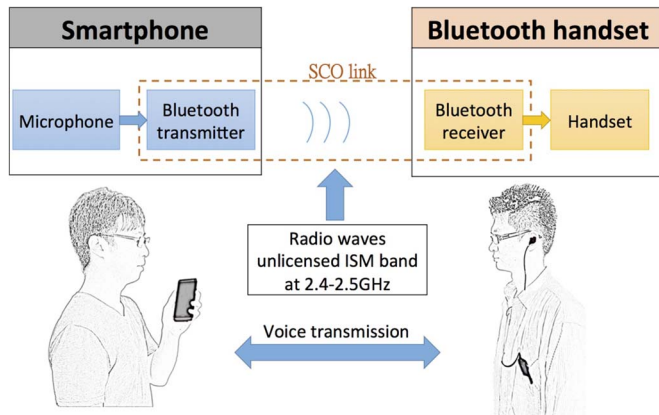

Fig. 2. System architecture of SmartHear. The listener (shown at the right) listens to the talker (shown at the left) at a distance using SmartHear.

TABLE I
SPECIFICATIONS OF SMARTHEAR

Module	Items	Specifications
Smartphone	CPU	Quad-core 1.7 GHz Krait 300
	OS	Android 4.4.2
Bluetooth handset	Bluetooth	v4.0 with A2DP
	Bluetooth	v3.0
	Headphone connector	3.5 mm
Headphones	Compatible	Bluetooth enabled smartphones, tablets and computers
	Ear coupling	Insert
	Nominal impedance	18 ± 3 ohm
	Driver type	Electro-dynamic
	Frequency range	20–20000 Hz
	Sensitivity	100.5 dB SPL/mW at 1 kHz
	Total harmonic distortion	< 0.5% (100–10000 Hz at 1 mW)



Fig. 3. Hardware components of SmartHear, including the smartphone, Bluetooth handset, and headphones.

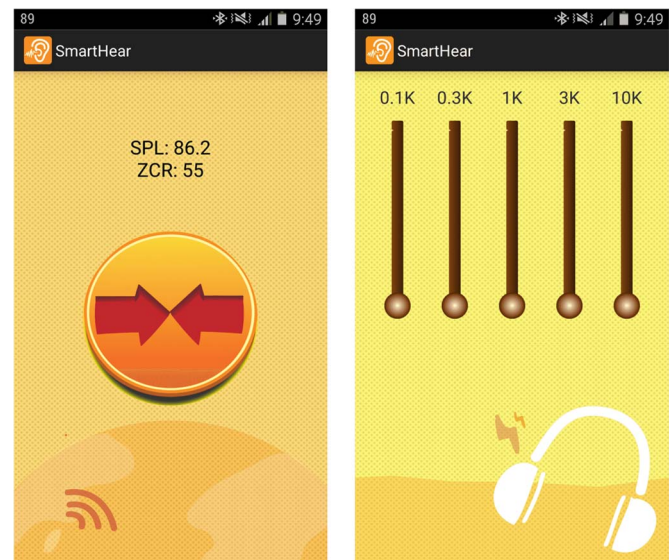

Fig. 4. Mobile application with an intuitive user interface for SmartHear.

connection-oriented (SCO) link, which is a type of baseband links mainly used for voice transmission, is established for point-to-point connection between the smartphone and the Bluetooth handset. The Bluetooth handset receives the radio waves and converts the PCM signal back to an analog signal for listening. Due to the proximity between the smartphone and the talker, and the transmission of voice signals over radio waves without reverberation and ambient noise effects, the listener can listen to the voice uttered from a distance with more ease. Fig. 3 shows the hardware components of SmartHear, including the smartphone, Bluetooth handset, and headphones (earbuds), with detailed specifications summarized in Table I.

To facilitate the use of our system by elderly people with mild-to-moderate HL, we develop a mobile application with an intuitive user interface, as shown in Fig. 4. The user only needs to press one button that initiates and completes the connection process in the SmartHear system. In addition, SmartHear can be easily customized to different people with different degrees/configurations of HL. The user can adjust the amplification in each of the five frequency channels (0.1, 0.3, 1, 3, and 10 kHz), as shown in Fig. 4, according to his/her audiogram or personal preferences. Furthermore, the user interface shows the

sound characteristics at the top of the display screen, including the sound pressure level (SPL) and zero-crossing rate (ZCR), which can be used for advanced speech–audio processing in an extension of SmartHear.

The connection between the smartphone and the Bluetooth handset is established in five stages, as described in Fig. 5. In stage 1, the Bluetooth Android application programming interface (API) turns on the Bluetooth application, if the Bluetooth status is currently off. The Bluetooth API also checks whether Bluetooth is supported on this smartphone. In stage 2, the Bluetooth API finds Bluetooth handsets either through discovering devices or by querying the list of bonded devices. If the Bluetooth handset has been paired with the smartphone previously, the Bluetooth API searches the Bluetooth handset on the bonded list. Once the Bluetooth handset is identified, the application is ready to connect. If the smartphone has never been paired with any Bluetooth handset previously, the Bluetooth API starts the discovering mode and scans the surrounding device, which lasts about 12 s. Once a Bluetooth handset

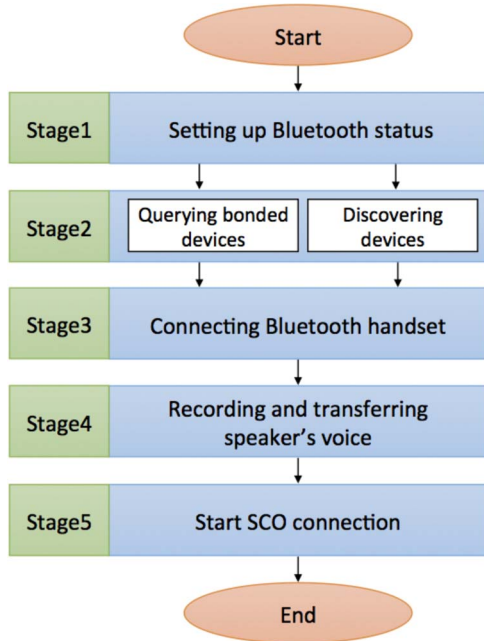

Fig. 5. Flowchart of the five stages of establishing the connection between the smartphone and the Bluetooth handset.

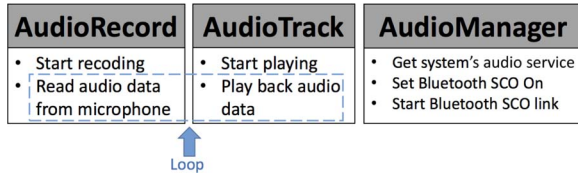

Fig. 6. Three main APIs for establishing the SCO link.

is identified, it stops scanning and tries to pair with the device. The pairing mechanism is the secure simple pairing, which does not require the user to enter any personal identification number codes. When the pairing procedure completes, the Bluetooth API receives information from the Bluetooth handset, such as the device name, device class, media access control (MAC) address, etc. In stage 3, after successful pairing, the Bluetooth API tries to connect to the Bluetooth handset with a shared link key (which is used to distinguish the same Bluetooth handset) to build an encrypted connection. In stage 4, the audio API starts to record the talker's voice in the format of the PCM signal and sends it to the Bluetooth transmitter. In stage 5, the Bluetooth API establishes the SCO link between the smartphone and the Bluetooth handset to complete the entire process.

There are three main APIs to establish the SCO link to route the audio from the smartphone to the Bluetooth handset in SmartHear, i.e., AudioRecord, AudioTrack, and AudioManager, as shown in Fig. 6. The AudioRecord manages sound recording, and the AudioTrack manages sound playing. Both are set according to the parameters summarized in Table II. There are four options of sampling rates, i.e., 11.025, 16, 22.05, and 44.1 kHz. The higher the sampling rate, the longer the latency. Thus, for real-time audio applications such as SmartHear, we select the 11.025-kHz sampling rate. Mono sound format is used in our system, which is supported by most of the Bluetooth

TABLE II
SETTINGS FOR AUDIO BUFFER IN RECORDING AND PLAYING

Parameter	Value
Sampling rate	11.025 kHz
Audio channel	Mono
Audio format	PCM in 16 bits
Audio buffersize	640 bytes

devices. Most existing audio devices support the 16-bit PCM format and not the 8-bit PCM format. In order not to overwrite the audio buffer when it is written by the AudioRecord, the audio buffer is set to 640 bytes. After these settings are done, the AudioRecord starts recording the sound, reading audio data from the register, and storing audio data into the audio buffer just created. Then, the AudioTrack starts playing the audio by extracting the audio data from the audio buffer and writing into the audio sink for playback. The task of recording the talker's voice and playing it back simultaneously is repeated in a loop. Then, the AudioManager establishes the Bluetooth SCO, which redirects the audio path from the smartphone to the Bluetooth handset.

The mobile application for SmartHear is available for download on Google Play, and a video introduction to SmartHear is available on [29].

IV. EVALUATION METHODS

A. SII Test

We evaluate the performance of our system by the speech intelligibility index (SII), which is a standardized measure of intelligibility [30]. SII is a proportional value that sums importance-weighted speech audibility across frequencies, including corrections and computational procedures for the effects of distortion associated with inputs, reverberation, and masking [31]. The SII represents the amount of speech that is audible for an individual with HL in aided or unaided conditions. The SII can be expressed as follows:

$$\text{SII} = \sum_{n=1}^N I_n A_n \quad (1)$$

where N is the number of frequency bands; A_n is the audibility for the n th band; and I_n is the band importance function value of the n th band, which is based on ANSI standard [30]. I_n and A_n are determined by three input parameters: equivalent speech spectrum level, equivalent noise spectrum level, and hearing threshold levels. Equivalent speech spectrum level and equivalent noise spectrum level are obtained from the long-term spectrum, which is divided into 1/3-octave bands, and its power is computed. A total of 18 1/3-octave bands within 150–8000 Hz are used in this paper. Hearing threshold levels can be defined by the user. The SII value maps to the speech intelligibility score, according to the matching table provided by Verifit User's Guide [32]. The speech intelligibility score ranges from 0 to 1.

We consider four typical audiograms for mild-to-moderate HL [27], [28] in our experiment, as shown in Fig. 7. The four audiograms can be divided into two groups, namely, *precipitous*

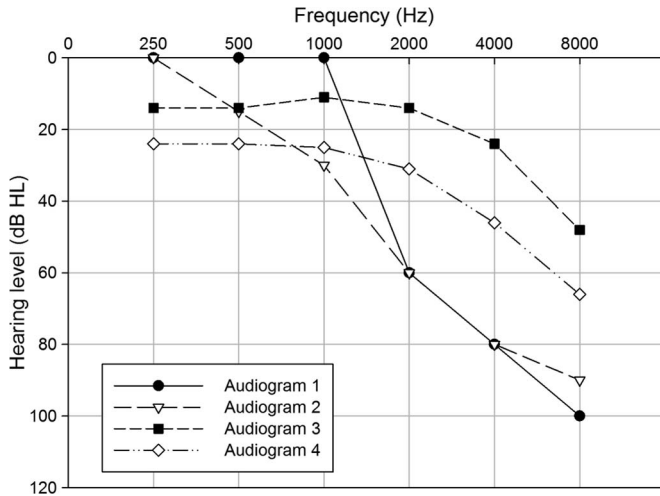

Fig. 7. Four typical audiograms for mild-to-moderate HL [27], [28] in the SII testing.

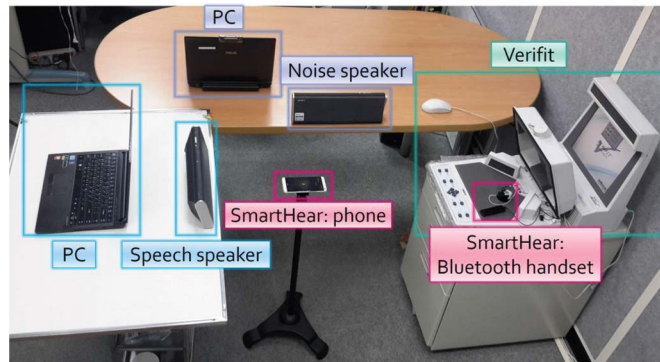

Fig. 8. Experimental setup for SII testing for SmartHear.

and *sloping*, according to the shape of audiometric configurations [27]. Audiogram 1 and Audiogram 2 are precipitous audiograms, and Audiogram 3 and Audiogram 4 are sloping audiograms. We adopt the four-frequency average HL (4FAHL), which is the average of thresholds at 500, 1000, 2000, and 4000 Hz, to indicate the degrees of HL. In the two groups of audiograms, audiogram 1 has a smaller 4FAHL value than audiogram 2, and audiogram 3 has a smaller 4FAHL value than audiogram 4. The testing data (IEEE sentences) and the implementation software (the MATLAB code) for calculating the SII value are provided in [31]. Each IEEE sentence is randomly selected among the 72 lists, and its duration is designed to last more than 13 s. The energy of all the sentences is normalized to the value of 3276 (corresponds to 70-dB SPL), where the maximum volume of the speaker is 32768 (corresponds to 90-dB SPL).

Our experimental setup is shown in Fig. 8. The speech speaker plays the IEEE sentences, and the noise speaker plays the speech-shaped noise (SSN). The Verifit Real-Ear Hearing Aid Analyzer model (VF-1) made by Audioscan is used to calculate the equivalent sound spectrum level for the various sounds from both speakers and SmartHear. The Verifit system is also used to facilitate the sound level calibration process. The volume of the noise speaker is calibrated at 70-dB SPL.

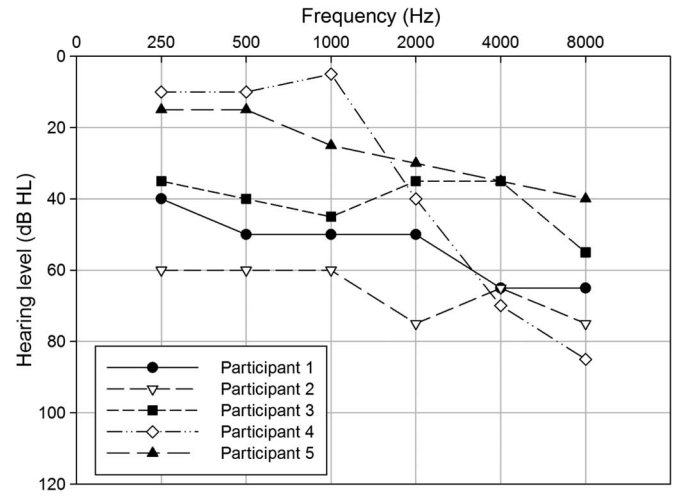

Fig. 9. Audiograms for the tested ear of the five participants in the user experience survey.

B. User Experience Questionnaire

We evaluate the user experience with SmartHear, in comparison with the conventional FM system, through a questionnaire-based survey. Five participants (three males and two females, aged 34–70 years with a mean age of 49 years), whose audiograms for the tested ear are shown in Fig. 9, participated in this survey. The configurations of these participants' HLs are similar to the four typical audiograms considered in the SII testing. Each participant was given a trial of the SmartHear device and a conventional personal FM system by listening to recorded materials using each device. The FM transmitter used for the study was the Phonak inspiro with a lapel microphone coupled to the transmitter (as shown in Fig. 1). The FM receiver was the Phonak iSense Micro, which was a small behind-the-ear headset designed for hearing-impaired users who do not wear hearing aids. At the beginning of the trial session, the participants received a copy of the user experience questionnaire, and they were given instructions and explanations regarding each item on the questionnaire. During the trial session, each participant was instructed to set the SmartHear device or the conventional FM system to a comfortable listening level (which was kept constant throughout the testing) and wear the device in the better ear. In the event that the participant has symmetric HL, he/she was asked to wear the device in the ear used to listen to the telephone in daily life. At the end of the device trials, the participant was asked to rate items regarding different situations on the questionnaire. This study was reviewed and approved by the local institutional review board (IRB) committees. Informed consent was obtained from all participants. All participants were compensated for their participation in this study.

We developed the user experience questionnaire based on the Satisfaction with Amplification in Daily Living (SADL) questionnaire [33], with modifications. The original SADL questionnaire aims to investigate hearing aid satisfaction. As shown in Table III, the questionnaire contains 17 items representing six dimensions: *positive effect* (4 items), *self-confidence* (3 items), *appearance* (3 items), *cost* (2 items), *ease of use* (3 items), and *willingness to purchase* (2 items). The questionnaire was

TABLE III
QUESTIONS ON THE USER EXPERIENCE QUESTIONNAIRE
(ASTERISKS INDICATE REVERSED ITEMS)

POSITIVE EFFECT	
1.	The sound from this hearing assistive system is natural.
2.	This hearing assistive system reduces the number of times I have to ask people to repeat.
10.	Compared to not using it, this hearing assistive system helps me understand better the people I speak with.
*14.	I am frustrated when this hearing assistive system picks up sounds that seem different from what I want to hear.
SELF-CONFIDENCE	
6.	This hearing assistive system improves my self-confidence in a conversation.
*8.	This hearing assistive system seems inconvenient to use on a regular basis.
*12.	I think using this hearing assistive system can cause inconvenience to others.
APPEARANCE	
*3.	Using this hearing assistive system makes me seem less capable.
*4.	I think people may notice my hearing loss when I use this hearing assistive system.
13.	I am content with my appearance when using this hearing assistive system.
COST	
5.	The cost of this hearing assistive system seems reasonable to me.
*11.	This hearing assistive system is barely affordable to me.
EASE OF USE	
7.	I can handle this hearing assistive system without help from others.
9.	I encounter no technical difficulty when using this hearing assistive system.
15.	This hearing assistive system is easy to use.
WILLINGNESS TO PURCHASE	
16.	I will consider this hearing assistive system when I need hearing assistance.
17.	I will recommend this hearing assistive system to relatives and friends.

presented to the participants in the order of the numbered items. The dimensions are not shown to the participants. Each item was rated on a seven-point rating scale from 1 (“strongly disagree”) to 7 (“strongly agree”). Reversed items are assigned reverse scores (e.g., an item receiving the rating of 1 will be assigned the score of 7). The average score was calculated for each dimension from responses to the corresponding items.

V. RESULTS

A. SII Test

We measure and compare the intelligibility performance of people with different degrees/configurations of HL in different SNR conditions and different cases (i.e., using SmartHear or not). The intelligibility scores were obtained in several steps. First, the speech of IEEE sentences and the SSN noise were received and analyzed by VF-1. Second, in order to compute the SII value, the output result from VF-1 and the typical audiograms were fed into the SII computation in MATLAB.

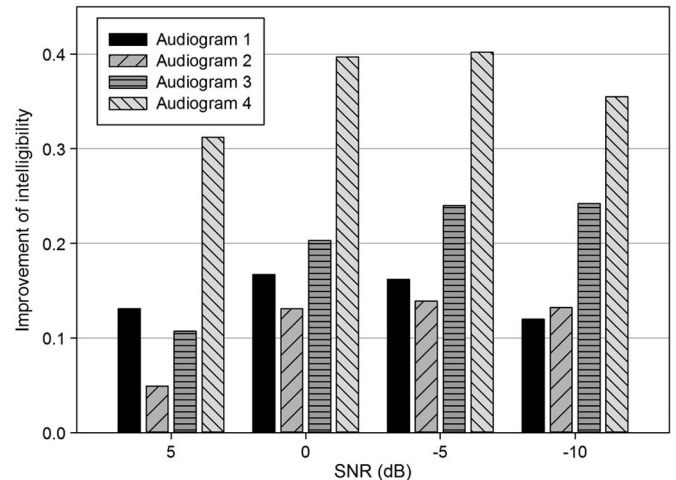

Fig. 10. Improvements in the speech intelligibility scores by using SmartHear, for the four audiograms in Fig. 7 and in four SNR conditions (5, 0, -5, and -10 dB). Positive values indicate better speech intelligibility performance by using SmartHear, as compared to not using SmartHear, in the corresponding condition.

Third, according to the matching table provided by Verifit User’s Guide, we mapped the SII value to the intelligibility. Finally, repeating all the steps in different SNR conditions, the intelligibility scores for the four typical audiograms in four SNR conditions were obtained.

Fig. 10 shows the improvement in the speech intelligibility score when SmartHear is used, for the four typical audiograms for mild-to-moderate HL and in four SNR conditions. As can be seen, SmartHear yields a greater improvement in the sloping group (Audiogram 3 and Audiogram 4) than in the precipitous group (Audiogram 1 and Audiogram 2) in general and particularly when $\text{SNR} \leq 0$. In the sloping group, the improvement is proportional to the degree of HL (i.e., greater improvement for Audiogram 4 than Audiogram 3). In the precipitous group, however, the improvement is not proportional to the degree of HL. In addition, there is a heightened difference between Audiogram 1 and Audiogram 2 when $\text{SNR} = 5$.

Fig. 11 presents the Speechmap [32], which displays the relationship between hearing thresholds, loudness discomfort levels (LDLs), and the amplified speech spectrum. The white dotted line is the normal hearing threshold, and the red circled line represents an individual with a flat audiogram of 55-dB HL, which is the most severe degree of moderate HL. The asterisks are LDLs, which indicate points of uncomfortable sensitiveness to sound predicted from the degree of HL. The green shaded region is called the speech envelope. The top and bottom curves of the speech envelope represent the level in each band that is exceeded by 99% and 70% of the samples, respectively, and the middle curve represents the long-term average speech spectrum. If the speech envelope is above the hearing threshold, the speech will be detectable. The speech envelope entirely above the threshold will be maximally audible, and one that extends above the LDLs will be uncomfortable. Fig. 11 shows a sharp magnification decrease above 4 kHz, due to the specification of the Bluetooth system [34] that the spectrum of the sound at the transmitter side should be below 4 kHz and the spectrum above

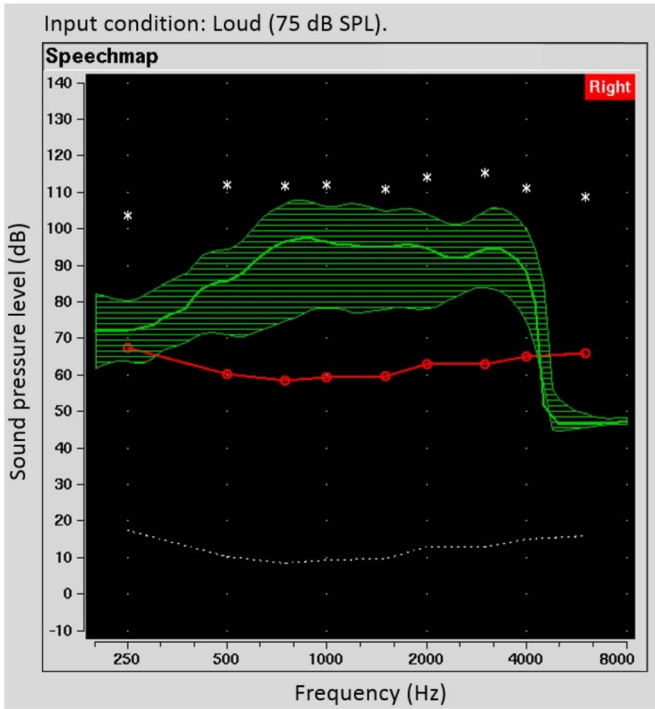

Fig. 11. Speechmap of sounds transmitted from SmartHear is shown in the green striped area. The red line (with circular markers) represents the hearing threshold of the upper limit of a moderate HL.

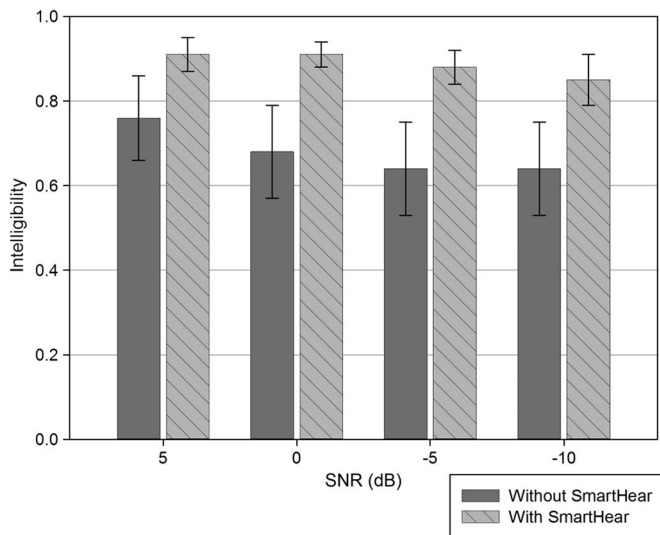

Fig. 12. Comparison of the average speech intelligibility scores (averaged over the four audiograms in Fig. 7) when using SmartHear or not, in four SNR conditions (5, 0, -5, and -10 dB). The error bars represent one standard deviation above and below the average scores.

4 kHz should be 20 dB below the maximum in the 0–4-kHz range at the receiver side.

Fig. 12 shows the speech intelligibility scores averaged over the four typical audiograms, when using SmartHear or not, in four SNR conditions. As can be seen, SmartHear can improve speech intelligibility for people with sloping and precipitous HL alike by approximately 0.2 score at each SNR condition. As the SNR decreases, the intelligibility generally decreases

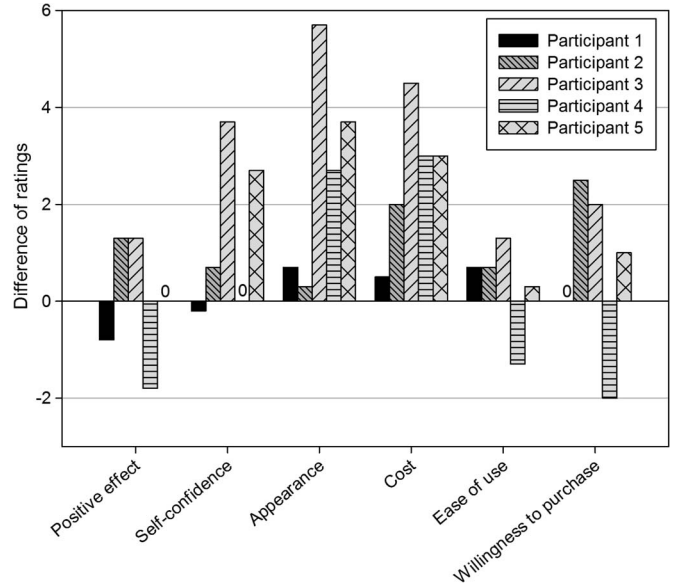

Fig. 13. Difference of average ratings (SmartHear subtracted by the conventional FM system) in the six dimensions in the user experience survey. Positive values indicate higher satisfaction of SmartHear in the corresponding dimensions.

more significantly when SmartHear is not used. The same score at $\text{SNR} = -5$ dB and -10 dB, when SmartHear is not used, indicates that it is difficult to distinguish the clean speech from the noise. In such challenging conditions, SmartHear can still achieve an average intelligibility score of 0.85 for people with HL.

B. User Experience Questionnaire

Fig. 13 shows the difference of average ratings (SmartHear subtracted by the conventional FM system) in the six dimensions in the user experience survey. Positive values represent higher satisfaction of SmartHear, and negative values represent higher satisfaction of the conventional FM system in the corresponding dimensions. As can be seen, SmartHear has a clear advantage in the dimensions of *self-confidence*, *appearance*, and *cost*. SmartHear and the conventional FM system received nearly the same preference ratings, on average, in the dimension of *positive effect*. For the dimensions of *ease of use* and *willingness to purchase*, most participants considered SmartHear more favorable, except for Participant 4.

VI. DISCUSSION

Fig. 10 observes a greater improvement for the sloping group when $\text{SNR} \leq 0$. As shown in Fig. 7, the hearing level in the precipitous group is higher than 55 dB (i.e., more severe than moderate HL) above 2 kHz, while the hearing level in the sloping group is generally below the degree of moderate HL, resulting in the higher benefits of using SmartHear for the sloping group. In the precipitous group, Audiogram 1 observes a greater improvement than Audiogram 2 at $\text{SNR} = 5, 0,$ and -5 dB. This may be due to the masking effect [30], [31]. The shape in Audiogram 1 (with better hearing at low frequencies)

intensifies the masking effect more than Audiogram 2, leading to a better intelligibility performance of Audiogram 2 than Audiogram 1 without SmartHear. On the other hand, since SmartHear equally magnifies all the speech spectrum below 4 kHz, the masking effect only mildly affects the intelligibility. Thus, Audiogram 1 exhibits a better intelligibility performance than Audiogram 2 with SmartHear.

Fig. 12 shows that there is a 0.1–0.15 score gap to full intelligibility when SmartHear is used. This may be explained as follows. First, most voice communication devices only transmit the sound below 4 kHz. Likewise, SmartHear only amplifies the sound below 4 kHz. However, the calculation of SII takes the sound spectrum between 4 and 8 kHz into account. Second, we adopt a relatively low sampling rate at 11.025 kHz in our configuration (see Table II), which may distort the original sound. It is an option to adopt a higher sampling rate for the sound quality at the tradeoff of transmission latency. Third, in our current configuration, SmartHear amplifies all the frequency channels at the same fixed amplification ratio of 17 dB. However, different types of HL require different fitting strategies. Developing a customized fitting strategy that maximizes the listening experience with SmartHear within the hardware capabilities is a worthwhile future study.

Fig. 13 shows an overall higher satisfaction toward SmartHear, as compared to the conventional FM system, according to our user experience survey. The results confirm the many attractive features of SmartHear based on user feedback. Specifically, the remarkable differences of ratings on the dimensions of *cost* and *willingness to purchase* justify the better affordability and cost effectiveness of SmartHear. The results for the dimension of *ease of use* suggest that the developed mobile application with an intuitive user interface meets the participants' needs and habits, making SmartHear a user-friendly device. Participant 4 gave low ratings for SmartHear on the dimensions of *ease of use* and *willingness to purchase*, possibly due to his/her preference of the conventional cell phone and lack of user experience with smartphones. The optimistic responses on the dimensions of *self-confidence* and *appearance* (particularly the unanimous and strong preference toward SmartHear in the dimension of *appearance*) verify the anti-stigma feature of SmartHear. The results for the dimension of *positive effect* suggest that the proposed SmartHear is comparable to the conventional commercial FM system, in terms of the sound quality of the device. Note that, in this user experience survey, the amplification scheme in SmartHear was not customized to the participant's audiogram. As mentioned earlier, a worthwhile future endeavor is to develop a customized fitting strategy for SmartHear, which may very likely further enhance the perceived sound quality of SmartHear. Participant 1 responded that he/she was not impressed by the sound from SmartHear, possibly due to the earphone not fitted to his/her ear and the insufficient amplification of the sound, which results in the poor performance on the dimension of *positive effect*. Participant 4's lower satisfaction with the sound quality of SmartHear on the dimension of *positive effect* may be related to his/her precipitous HL, as shown by the audiograms in Fig. 9. This lower satisfaction for Participant 4 with precipitous HL is in agreement with the SII testing results in Fig. 10, which shows that SmartHear yields

a smaller improvement in the precipitous group. This points to an important and promising future work for SmartHear: realize the full customization potential of SmartHear by adapting the amplification in each channel to the audiograms or preferences of users.

SmartHear is one of the many examples in mobile health, aiming to expand the smartphone hardware capabilities to potentially replace existing technologies. With increasingly more hearing-aid-related mobile applications launched in the iOS and Android mobile application stores, it can be anticipated that the hearing product industry will be changing, as individuals with HL can easily access affordable personal hearing assistance on smartphones. Few studies, however, address the issue of the scientific validity of these mobile hearing aid applications [35]. Our study presents the development of SmartHear and its validation process carried out in parallel, in an effort to provide the potential users with a scientifically proven hearing assistive technology on smartphones.

VII. CONCLUSION

We have developed a novel hearing assistive system using smartphones and wireless technologies for individuals with mild-to-moderate HL. The proposed SmartHear system is highly affordable and accessible compared to the existing commercially available FM systems, and it carries promising potential in customization and extension by designing advanced speech–audio processing techniques and user-friendly mobile applications. Our speech intelligibility experiments have shown an average improvement of 0.2 speech intelligibility score (on the scale of 0–1) across four typical audiograms for mild-to-moderate HL and in four SNR conditions. Our survey conducted among five participants with various degrees of HL compares the SmartHear and the conventional FM systems and confirms the many attractive features of SmartHear, including more affordability and cost effectiveness and less stigma. Future work includes developing a customized fitting strategy that maximizes the listening experience for users with different degrees/configurations of HL, incorporating advanced speech–audio processing techniques in our prototype system, promoting our proposed system by cooperating with local/global organizations serving people with HL, and establishing an effective user feedback mechanism.

REFERENCES

- [1] WHO Global Estimates on Prevalence of Hearing Loss, World Health Organization, Geneva, Switzerland, 2012. [Online]. Available: <http://www.who.int/pbd/deafness/estimates/en/>
- [2] E. P. Davila *et al.*, "Sensory impairment among older US workers," *Amer. J. Public Health*, vol. 99, no. 8, pp. 1378–1385, Aug. 2009.
- [3] J. G. W. Bernstein and K. W. Grant, "Auditory and auditory-visual intelligibility of speech in fluctuating maskers for normal-hearing and hearing-impaired listeners," *J. Acoust. Soc. Amer.*, vol. 125, no. 5, pp. 3358–3372, May 2009.
- [4] C. J. Darwin, "Listening to speech in the presence of other sounds," *Philos. Trans. Roy. Soc. London B, Biol. Sci.*, vol. 363, no. 1493, pp. 1011–1021, Mar. 2008.
- [5] H. Dillon, *Hearing Aids*. Stuttgart, Germany: Thieme, 2012.
- [6] B. C. Moore, "Speech processing for the hearing-impaired: Successes, failures, and implications for speech mechanisms," *Speech Commun.*, vol. 41, no. 1, pp. 81–91, Aug. 2003.

- [7] S. Arlinger, "Negative consequences of uncorrected hearing loss—A review," *Int. J. Audiol.*, vol. 42, no. S2, pp. 2S17–2S20, Jul. 2003.
- [8] M. K. Pichora-Fuller, K. Dupuis, M. Reed, and U. Lemke, "Helping older people with cognitive decline communicate: Hearing aids as part of a broader rehabilitation approach," *Semin. Hearing*, vol. 34, no. 4, pp. 308–330, 2013.
- [9] Y. Lotfi, S. Mehrkian, A. Moossavi, and S. Faghih-Zadeh, "Quality of life improvement in hearing-impaired elderly people after wearing a hearing aid," *Arch. Iranian Med.*, vol. 12, no. 4, pp. 365–370, Jul. 2009.
- [10] S. Kochkin, "Marketrak VII: Obstacles to adult non-user adoption of hearing aids," *Hearing J.*, vol. 60, no. 4, pp. 24–51, Apr. 2007.
- [11] S. Kochkin, "Marketrak VII: Customer satisfaction with hearing instruments in the digital age," *Hearing J.*, vol. 58, no. 9, pp. 30–32, Sep. 2005.
- [12] S. Kochkin, "Marketrak VIII: Consumer satisfaction with hearing aids is slowly increasing," *Hearing J.*, vol. 63, no. 1, pp. 19–20, Jan. 2010.
- [13] H.-W. Chang, "Frequency-modulated system: The learning tool for hearing-impaired students," *Deaf Educ.*, vol. 12, pp. 4–10, 2010.
- [14] Phonak FM Systems. [Online]. Available: <http://www.phonak.com/uk/b2c/en/products/fm.html>
- [15] Comtek AT-216 Personal FM Systems. [Online]. Available: http://www.teccar.com/Comtek_Personal_FM.htm
- [16] Comfort Contego. [Online]. Available: <http://www.ihear.co.uk/>
- [17] Comfort Contego. [Online]. Available: <http://www.comfortaudio.com/us/users/find-assistive-listening-device/product-overview/comfort-contego/>
- [18] A. Boothroyd, "Hearing aid accessories for adults: The remote FM microphone," *Ear Hearing*, vol. 25, no. 1, pp. 22–33, Feb. 2004.
- [19] L. Thibodeau, "Benefits of adaptive FM systems on speech recognition in noise for listeners who use hearing aids," *Amer. J. Audiol.*, vol. 19, no. 1, pp. 36–45, Jun. 2010.
- [20] L. Thibodeau, "Comparison of speech recognition with adaptive digital and FM remote microphone hearing assistance technology by listeners who use hearing aids," *Amer. J. Audiol.*, vol. 23, no. 2, pp. 201–210, Jun. 2014.
- [21] A. Donahue, J. R. Dubno, and L. Beck, "Accessible and affordable hearing health care for adults with mild to moderate hearing loss," *Ear Hearing*, vol. 31, no. 1, pp. 2–6, Feb. 2010.
- [22] M. S. Lewis, C. C. Crandell, M. Valente, and J. E. Horn, "Speech perception in noise: Directional microphones versus Frequency Modulation (FM) systems," *J. Amer. Acad. Audiol.*, vol. 15, no. 6, pp. 426–439, Jun. 2004.
- [23] J. Wolfe *et al.*, "Evaluation of speech recognition in noise with cochlear implants and dynamic FM," *J. Amer. Acad. Audiol.*, vol. 20, no. 7, pp. 409–421, Jul./Aug. 2009.
- [24] E. C. Schafer *et al.*, "Personal FM systems for children with Autism Spectrum Disorders (ASD) and/or Attention-Deficit Hyperactivity Disorder (ADHD): An initial investigation," *J. Commun. Disorders*, vol. 46, no. 1, pp. 30–52, Jan./Feb. 2013.
- [25] K. N. Johnston, A. B. John, N. V. Kreisman, J. W. Hall, III, and C. C. Crandell, "Multiple benefits of personal FM system use by children with Auditory Processing Disorder (APD)," *Int. J. Audiol.*, vol. 48, no. 6, pp. 371–383, 2009.
- [26] Sonova Holding AG, "Annual report 2010/2011," Stäfa, Switzerland, 2011.
- [27] B. Stach, *Clinical Audiology: An Introduction*. Boston, MA, USA: Cengage Learning, 2008.
- [28] Y.-H. Lai, Y. Tsao, and F. Chen, "A study of adaptive WDRC in hearing aids under noisy conditions," *Int. J. Speech Lang. Pathol. Audiol.*, vol. 1, no. 2, pp. 43–51, 2013.
- [29] SmartHear. [Online]. Available: <https://www.youtube.com/watch?v=e9Hqj09QJs>
- [30] American National Standards Institute, American National Standard: Methods for Calculation of the Speech Intelligibility Index, New York, NY, USA: Acoustical Society of America, 1997.
- [31] P. C. Loizou, *Speech Enhancement: Theory and Practice*. Boca Raton, FL, USA: CRC Press, 2013.
- [32] Verifit VF-1 Real-Ear Hearing Aid Analyzer User's Guide: Version 2.4.1, Audioscan Verifit, Dorchester, ON, Canada, 2005.
- [33] Satisfaction With Amplification in Daily Living. [Online]. Available: <http://www.harlmemphis.org/index.php/clinical-applications/sad/>
- [34] Specification of the Bluetooth System, Version 1.1, Bluetooth Special Interest Group, Kirkland, WA, USA, 2001, [Online]. Available: <http://www.bluetooth.com>
- [35] A. M. Amlani, B. Taylor, C. Levy, and R. Robbins, "Utility of smartphone-based hearing aid applications as a substitute to traditional hearing aids," *Hearing Rev.*, vol. 12, pp. 16–23, 2013.



Yu-Cheng Lin received the B.S. degree in mechanical engineering from the National Central University, Taoyuan, Taiwan, in 2010 and the M.S. degree in engineering science and ocean engineering from the National Taiwan University, Taipei, Taiwan, in 2013.

He is currently a Research Assistant with the Research Center for Information Technology Innovation, Academia Sinica, Taipei, Taiwan. His recent research interests include wireless assistive hearing technology and mobile application development.



Ying-Hui Lai received the B.S. degree in electrical engineering from the National Taiwan Normal University, Taipei, Taiwan, in 2005 and the Ph.D. degree in biomedical engineering from the National Yang-Ming University, Taipei, in 2013.

From 2010 to 2012, he was with Aescu Technologies, working on development of hearing aids. Since 2013, he has been a Postdoctoral Research Fellow with the Research Center for Information Technology Innovation, Academia Sinica, Taipei, Taiwan. His research interests focus on hearing aids, cochlear implants, noise reduction, pattern recognition, and source separation.

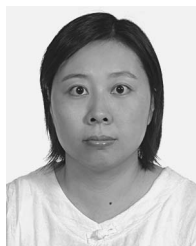

Hsiu-Wen Chang received the First Master's degree in linguistics from the National Chung Cheng University, Chiayi, Taiwan, in 1997; the Second Master's degree in audiology from Washington University in St. Louis, St. Louis, MO, USA, in 2001; and the Ph.D. degree in biomedical engineering from the National Yang-Ming University, Taipei, Taiwan, in 2012.

She is an Assistant Professor in audiology with the Department of Audiology and Speech-Language Pathology, MacKay Medical College, New Taipei, Taiwan. She has extensive clinical experience in adult and pediatric hearing services. She performs research into many aspects of audiology. Most recently, her research has concerned the mobile application development for hearing aids, the electrophysiological evaluation of hearing aid effectiveness in infants and young children, and the development of outcome assessment tools in Mandarin Chinese.

Dr. Chang is a Certified Audiologist. She also serves as an Executive Council Member of the Taiwan Speech-Language-Hearing Association.



Yu Tsao (M'09) received the B.S. and M.S. degrees in electrical engineering from the National Taiwan University, Taipei, Taiwan, in 1999 and 2001, respectively, and the Ph.D. degree in electrical and computer engineering from Georgia Institute of Technology, Atlanta, GA, USA, in 2008.

From 2009 to 2011, he was a Researcher with the National Institute of Information and Communications Technology, Japan, where he engaged in research and product development in automatic speech recognition for multilingual speech-to-speech translation. He is currently an Assistant Research Fellow with the Research Center for Information Technology Innovation, Academia Sinica, Taipei. His research interests include speech and speaker recognition, acoustic and language modeling, multimedia signal and information processing, pattern recognition, and machine learning.



Yi-ping Chang received the B.S. degree in electrical engineering from the National Tsing Hua University, Hsinchu, Taiwan, in 2000; the M.S. degree in electrical and control engineering from the National Chiao Tung University, Hsinchu, in 2002; and the Ph.D. degree in biomedical engineering from the University of Southern California, Los Angeles, CA, USA, in 2009. She also received the Graduate Certificate in Educational Studies with a specialization in Listening and Spoken Language from the University of Newcastle, Callaghan, Australia, in 2014.

From 2009 to 2010, she was a Postdoctoral Researcher with the House Ear Institute, Los Angeles. Since 2011, she has been with the Children's Hearing Foundation, Taipei, Taiwan, where she is currently the Director of the Speech and Hearing Science Research Institute. Her research interests include speech perception in cochlear implants, bimodal hearing, and assessment of listening and spoken language development of children with hearing loss.



Ronald Y. Chang (M'12) received the B.S. degree in electrical engineering from the National Tsing Hua University, Hsinchu, Taiwan, in 2000; the M.S. degree in electronics engineering from the National Chiao Tung University, Hsinchu, in 2002; and the Ph.D. degree in electrical engineering from the University of Southern California, Los Angeles, CA, USA, in 2008.

From 2002 to 2003, he was with the Industrial Technology Research Institute, Hsinchu. In 2008, he was a Research Intern with the Mitsubishi Electric Research Laboratories, Cambridge, MA, USA. Since 2010, he has been with the Research Center for Information Technology Innovation, Academia Sinica, Taipei, Taiwan, where he is currently an Assistant Research Fellow. He is the holder of four U.S. patents. His research interests include wireless communications and networking.

Dr. Chang was an exemplary reviewer for the IEEE COMMUNICATIONS LETTERS in 2012. He was a recipient of the Best Paper Award from the IEEE Wireless Communications and Networking Conference in 2012 and the Outstanding Young Scholar Award from the Ministry of Science and Technology, Taiwan, in 2015.